



DIECI

ICARUS

40.14 | 40.17 | 50.18



NEW CONSTRUCTION ***THE CONSTRUCTION SITE IN YOUR HANDS***

The needs on construction sites are changing: management costs must be reduced, the vehicles productivity must be continuously improved. And Dieci meets its customers new requirements, evolving its own Product Offering with a new proposal of models that completes the Construction range.

More versatile vehicles - to perform different jobs - more **robust**, more **reliable**, **easy** and intuitive to use, while guaranteeing the maximum safety at all times. Maintenance is very easy thanks to **durable** components and materials that require replacement after several hundred hours of use. Modern vehicle, even in the lines, with the new Giugiaro Design cab enriched with materials derived from Truck and Automotive sectors that enhance its interiors.

ICARUS, in the new Construction GD range, is the vehicle that reaches great heights: the boom of the 50.18 model can extend up to 17,8 meters, guaranteeing maximum stability thanks to the new rear outrigger cylinder. The wide range of equipment available allow to carry out various operations: with a telehandler, **you have the whole construction site in your hands.**

STRONG AND SAFE

POWERFUL AND STABLE

- **Extremely rugged** vehicles with **exceptional loading capacities** in all operating conditions, with boom retracted or extended
- **High efficiency Kubota engines:** low noise, low consumption and low emissions
- **Arm too high** function: forward movement speed limited automatically when the boom is raised
- **Increased lateral stability:** longer wheelbase and robust chassis
- **Rear stabilizer cylinder:** rear axle locked when the boom is at maximum height*
- **EN15000 anti-tipping system:** aggravating movements blocked in the event of overload and load level always in evidence
- **ROPS and FOPS Cab:** operator protection guaranteed thanks to the dimensional stability of the cab
- **Independent outriggers** with proportional controls
- **Transversal leveling device:** to always work with the chassis in horizontal position, even on uneven ground.

* only for Icarus 50.18



GREAT LOADING CAPACITIES

ARM TOO HIGH

ROPS - FOPS

ICARUS 40.14

- ↑ Height 13,4 m
- 📊 Capacity 4000 kg
- ⚡ Power 85,1 kw@2600 rpm
- 📖 Mass 10900 kg



ICARUS 40.17

- ↑ Height 16,4 m
- 📊 Capacity 4000 kg
- ⚡ Power 85,1 kw@2600 rpm
- 📖 Mass 12260 kg



ICARUS 50.18

- ↑ Height 17,8 m
- 📊 Capacity 5000 kg
- ⚡ Power 85,1 kw@2600 rpm
- 📖 Mass 14750 kg



VERSATILE AND FLEXIBLE

WIDE RANGE OF EQUIPMENT

- The new Icarus vehicles have been designed to use the **various equipment** needed to carry out **all the work required by a construction site**: forks, loaders, lifting hooks, jibs with winches, grippers, material baskets, mixing buckets, concrete ladles, sweepers, salt spreader, snowplow blades

- **Automatic equipment recognition**: the vehicle configures itself automatically recognizing the equipment attached
- **Pre-arrangement for man basket**: the remote control allows the operator to operate the boom and the aerial platform directly from the basket, in total autonomy and full safety (complies with the EN 280 standard)



EASY AND INTUITIVE

INTELLIGENT COMMANDS

- All boom movements are controlled by a **single joystick**, in a precise and proportional way and regardless of the load
- Dashboard with clear instrument panel and **well-distributed controls**
- **Automatic electric parking brake**, even with the engine off: hill-start assist always available
- **Joystick with integrated FNR**, with capacitive sensor to automatically detect the operator's presence
- Vehicle information and diagnostic menu browsable in the 3.5" display

INTEGRATED FNR

PARKING BRAKE



PRACTICAL AND RELIABLE

FACILITATED DRIVING AND MAINTENANCE

- **Four driving wheels** and four steering wheels
- **Three steering modes** which can be selected by the operator: concentric, front and crab
- Hydraulic oil change every **2000 hours**
- **Easy to reach filters** in the engine compartment
- Sturdy and durable boom assembly: **tested reliability** for years of multiple applications and uses.
- **Standard battery isolation switch**, well protected and quickly accessible from the engine compartment

4 DRIVE WHEELS

OIL: 2000 HOURS

TECHNOLOGICAL EFFICIENCY

DIECI HARDWARE AND SOFTWARE

- **Hydrostatic transmission** with fully electronic control
- **New control software** developed by the Dieci R&D department: advanced boom, vehicle, engine, transmission and exhaust treatment control
- **Low consumption, high efficiency, optimized yield and maximum safety** in all the vehicle conditions of use
- **ECO function**: maximum speed already at 2200 rpm, automatically managed by the control unit according to the power required by the operator
- High-strength steel structures produced internally by Dieci: **top market performance**

NEW SOFTWARE

LOW CONSUMPTION



COMFORT AND CONTROL

NEW GIUGIARO DESIGN

- **New Giugiaro Design** cab: fine interiors derived from the Truck and Automotive sectors
- **More space** for the operator's legs
- Adjustable steering column and armrest
- **Three seat suspension systems** to choose from: mechanical, pneumatic and low frequency pneumatic
- Soundproofing roof, dashboard and mat
- Large windows
- Integrated **LED work lights** for maximum visibility even at night: on the cab, boom and perimeter
- Rear-view mirrors that allow all-round visibility and **optional cameras**
- Direction of travel and boom controlled by the **new ergonomic joystick**

TECHNICAL DATA

PERFORMANCE

| Vehicle model | ICARUS 40.14 - GD | ICARUS 40.17 - GD | ICARUS 50.18 - GD |
|--|----------------------|----------------------|-----------------------|
| Maximum capacity | 4000 kg (8818 lb) | 4000 kg (8818 lb) | 5000 kg (11023 lb) |
| Maximum lifting height | 13,40 m (44 ft) | 16,40 m (54,5 ft) | 17,80 m (58,4 ft) |
| Pull-out force | 5700 daN (12814 lbf) | 5700 daN (12814 lbf) | 5700 daN (12814 lbf) |
| Towing force | 9300 daN (20907 lbf) | 9300 daN (20907 lbf) | 11600 daN (26078 lbf) |
| Maximum climb angle | 40% | 40% | 40% |
| Unladen weight | 10900 kg (24030 lb) | 12260 kg (27029 lb) | 14750 kg (32518 lb) |
| Max speed (referred to wheels with maximum permitted diameter) | 38 km/h (23,6 mph) | 38 km/h (23,6 mph) | 27 km/h (16,8 mph) |

ENGINE

| Vehicle model | ICARUS 40.14 - GD | ICARUS 40.17 - GD | ICARUS 50.18 - GD |
|-----------------------|---------------------------|---------------------------|---------------------------|
| Brand | Kubota | Kubota | Kubota |
| Nominal power | 85,1 kW (114 HP) | 85,1 kW (114 HP) | 85,1 kW (114 HP) |
| @rpm | 2600 rpm | 2600 rpm | 2600 rpm |
| Displacement | 3769 cm³ (230 in³) | 3769 cm³ (230 in³) | 3769 cm³ (230 in³) |
| Emission standard | Stage IV/Tier 4f | Stage IV/Tier 4f | Stage IV/Tier 4f |
| Exhaust gas treatment | DOC+DPF+SCR | DOC+DPF+SCR | DOC+DPF+SCR |
| Intake | Turbocharger after-cooler | Turbocharger after-cooler | Turbocharger after-cooler |

HYDRAULIC SYSTEM

| | |
|-------------------------|--|
| Hydraulic pump type | Dual gear pump for power steering and movements |
| Hydraulic pump capacity | 140 L/min (37 gal/min) |
| Max. operating pressure | 25,0 MPa (3626 psi) |
| Distributor control | 4 in 1 proportional Joystick |
| Outriggers | 2 with proportional control and independent from the cab |

TRANSMISSION

| | |
|----------------------|--|
| Transmission type | Hydrostatic with electronic control with variable displacement pump and ECO function |
| Hydraulic motor | Hydrostatic with continuous automatic adjustment |
| Reversal | With electronic control operated with vehicle in motion |
| Inching | With electronic pedal for controlled forward movement |
| Transmission gearbox | Servo-controlled 2-speed |

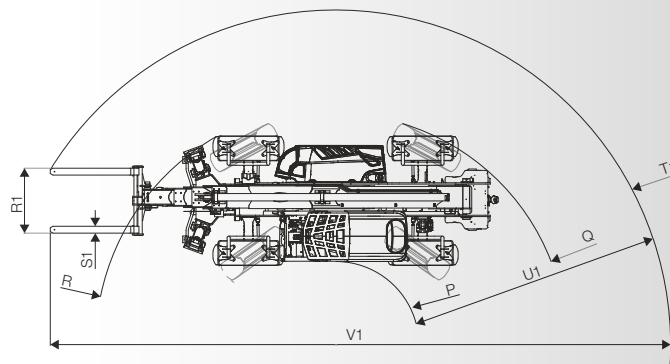
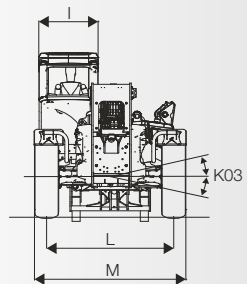
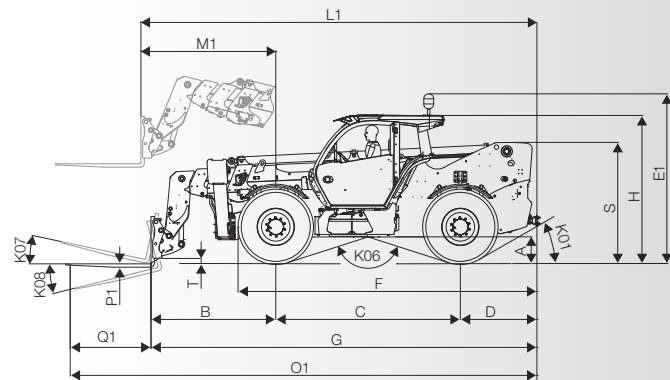

DIMENSIONS

| | ICARUS 40.14 - GD | ICARUS 40.17 - GD | ICARUS 50.18 - GD |
|-----|---------------------|---------------------|---------------------|
| A | 390 mm (15,4 in) | 390 mm (15,4 in) | 480 mm (18,9 in) |
| B | 1900 mm (74,8 in) | 1960 mm (77,2 in) | 2230 mm (87,8 in) |
| C | 3050 mm (120,1 in) | 3050 mm (120,1 in) | 3300 mm (129,9 in) |
| D | 1255 mm (49,4 in) | 1255 mm (49,4 in) | 1370 mm (53,9 in) |
| E1 | 2805 mm (110,4 in) | 2805 mm (110,4 in) | 2925 mm (115,2 in) |
| F | 4890 mm (192,5 in) | 4890 mm (192,5 in) | 5900 mm (232,3 in) |
| G | 6200 mm (244,1 in) | 6250 mm (246,1 in) | 6900 mm (271,7 in) |
| H | 2530 mm (99,6 in) | 2530 mm (99,6 in) | 2650 mm (104,3 in) |
| I | 960 mm (37,8 in) | 960 mm (37,8 in) | 960 mm (37,8 in) |
| K01 | 32° | 32° | 30° |
| K03 | 10° | 10° | 10° |
| K06 | 147° | 147° | 145° |
| K07 | 14° | 14° | 14° |
| K08 | 120° | 120° | 120° |
| L | 1970 mm (77,6 in) | 1970 mm (77,6 in) | 2050 mm (80,7 in) |
| L1 | 6340 mm (249,6 in) | 6455 mm (254,1 in) | 7080 mm (278,7 in) |
| M | 2390 mm (94,1 in) | 2390 mm (94,1 in) | 2440 mm (96,1 in) |
| M1 | 2100 mm (82,7 in) | 2030 mm (79,9 in) | 2411 mm (94,9 in) |
| O1 | 7400 mm (291,3 in) | 7465 mm (293,9 in) | 8345 mm (328,5 in) |
| P | 1405 mm (55,3 in) | 1405 mm (55,3 in) | 1579 mm (62,2 in) |
| P1 | 50 mm (2 in) | 50 mm (2 in) | 60 mm (2,4 in) |
| Q | 4140 mm (163 in) | 4140 mm (163 in) | 4379 mm (172,4 in) |
| Q1 | 1200 mm (47,2 in) | 1200 mm (47,2 in) | 1525 mm (60 in) |
| R | 4140 mm (163 in) | 4140 mm (163 in) | 4547 mm (179 in) |
| R1 | 1220 mm (48 in) | 1220 mm (48 in) | 1230 mm (48,4 in) |
| S | 1800 mm (70,9 in) | 1800 mm (70,9 in) | 2162 mm (85,1 in) |
| S1 | 120 mm (4,7 in) | 120 mm (4,7 in) | 130 mm (5,1 in) |
| T | 155 mm (6,1 in) | 180 mm (7,1 in) | 100 mm (3,9 in) |
| T1 | 5635 mm (221,9 in) | 5675 mm (223,4 in) | 6342 mm (249,7 in) |
| U1 | 4230 mm (166,5 in) | 4275 mm (168,3 in) | 4767 mm (187,7 in) |
| V1 | 10260 mm (403,9 in) | 10360 mm (407,9 in) | 11730 mm (461,8 in) |

MAX
4000 kg / 8818 lb

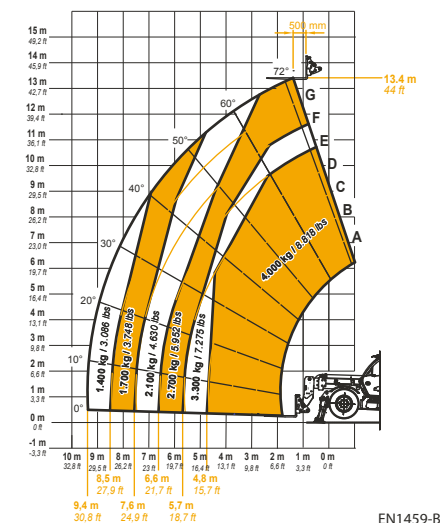

EN1459-B

40.14

MAX
4000 kg / 8818 lb

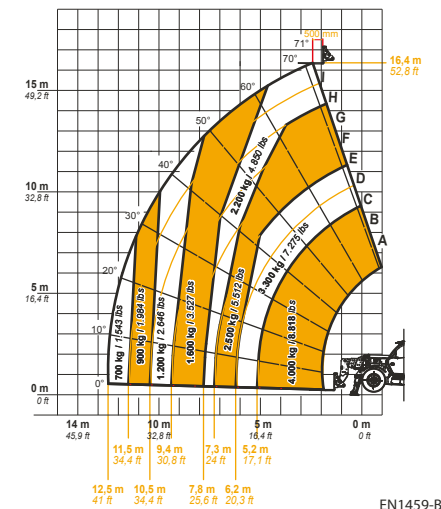

EN1459-B

40.17

MAX
4999 kg

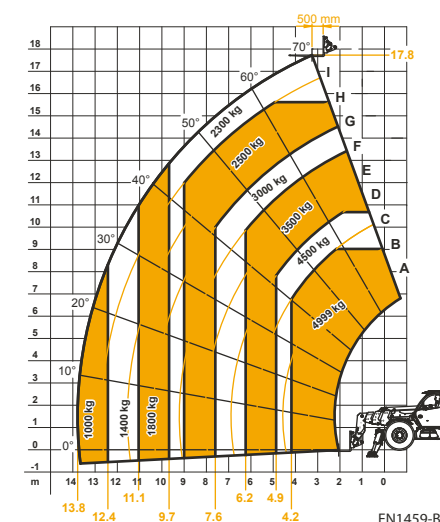

EN1459-B

50.18

DIECI SERVICE

ASSISTANCE SERVICE ALWAYS AND EVERYWHERE

General headquarters in Emilia Romagna - over 135,000 square meters and about 400 people employed - and 3 branches in Germany, United Kingdom, France: Dieci is present in over 70 Countries with **an extensive network of over 400 dealers** and authorized service centers.

Dieci Service, our global technical assistance service, is developed on this basis: our customers are assisted directly by specialized technicians and every request is satisfied in a very short time. Dieci Service, **within a few hours, can provide interventions and spare parts all over the world.**

Visit www.dieci.com to find the dealer closest to you.

400 **DEALERS**

70 **COUNTRIES**

3 **BRANCHES**



ICARUS

40.14 | 40.17 | 50.18

DIECI

www.dieci.com

